

Safe System of Work – Operation of LEV - ProfiMaster

The ProfiMaster device was developed and designed in accordance with the current state of the art and established technical safety guidelines. Operating the ProfiMaster device may be associated with risks to the operator, resp. the risk of damage to the instrument or other property damage if it is:

- operated by untrained or uninformed staff,
- used contrary to its purpose and/or
- improperly maintained.

YOU MUST NOT OPERATE THIS EQUIPMENT IF YOU HAVE NOT ATTENDED THE APPROPRIATE TRAINING COURSE.

Pre-Operation

Personal Safety

➤ **What is the task?**

Make sure you have thought through exactly what any new task involves before you start.

➤ **Do I understand how to do the task correctly?**

- Have I been trained?
- Am I competent?
- Is it a familiar task – or a one-off that I may not be able to tackle?

If you are sure you are trained and competent then carry on. If not **STOP** and refer to your supervisor.

➤ **Do I have the right tools and equipment?**

Make sure you use the right kit in the right way:

- Is it in good condition or is it damaged?
- Is it up to the job?

If the equipment is ok, then carry on. If not, **STOP** and refer to your supervisor.

➤ **Do I know who or what may be harmed?**

- Am I aware of the hazards?
- Am I aware of other people in the area?

If you aren't aware of what could hurt you or your colleagues, how will you protect yourself and them? If you are not sure, **STOP** and refer to your supervisors.

Safe System of Work – LEV				Page 1 of 5	
Document Ref:	SSW004	Issue:	1	Date:	06/19



➤ **Are controls in place?**

If you know what the hazards are, what controls are there in place to minimise the risks?

- Guards
- Procedures
- PPE/RPE
- Exclusion zones
- Inspections

If you do know what the controls are make sure they are in place. If they are not, **STOP** and refer to your supervisor.

Pre-use checks

Pre-use checks need to be completed to ensure the equipment is safe and to identify any defects present.

- Ensure that the Daily First use check sheet has been completed. No warning lights lit up
- Always complete a visual check each time you use the equipment
- Check to ensure that there is no obvious damage to the casing of the control unit.

Operation

The ProfiMaster device may only be used by individuals familiar in using this device in order to use the unit independently. Becoming familiar with this device includes receiving training and having knowledge of this Instruction Manual or other relevant operating instructions.

The ProfiMaster device may only be used by trained and knowledgeable staff. This is the only way to achieve safe operation of the unit with regard to the impending dangers.

Control elements

On the front side of the ProfiMaster device there are controls and connections:

Switch I / O (1)

Press this switch to turn the device on and off. A green signal light in the switch control panel indicates the trouble-free operation of the unit, i.e. its operability when using the optional Start/Stop sensor.

LED indicator lamp (2)

If the yellow signal light is on, it may indicate the following failures:

- Motor protection relay has responded
- Error of the sequence of phases / missing phase
- Filter replacement is necessary

Recessed hole for the Start/Stop terminal (3)

Recessed hole for automatic Start/Stop optional unit

Safe System of Work – LEV				Page 2 of 5	
Document Ref:	SSW004	Issue:	1	Date:	06/19



Pressure measurement opening (4)

Connection for KEMPER service. Through this connection the KEMPER service department can perform pressure measurements.

Horn (5)

The safe collection of welding fumes is only possible with a sufficient suction power. Increasing filter clogging with dust makes the flow resistance grow and hence the suction power is reduced. The horn starts sounding as soon as the level drops below the specified minimum value. Now it is time to replace the filter.

The same occurs when the control valve in the extraction nozzle is closed too tightly, which also significantly reduces the suction power. This can be corrected by opening the control valve.

Pressure switch (6)

Using this interface, the KEMPER service department can make settings on the device. Intended only for KEMPER service.

Pos.	Designation	Note
1	On / Off switch	
2	LED indicator lamp	
3	Recessed hole for the Start/Stop terminal (*3) (plugged with a closing plug)	
4	Hole for pressure measuring (for service personnel only)	
5	Horn	
6	Pressure switch (plugged with a closing plug) (for service personnel only)	



*3 Optional equipment



Adjusting the position of the extraction nozzle

To ensure the sufficient suction of welding fumes, it is important for the exhaust nozzle to be in the correct position all the time. The correct position is shown in the following picture.

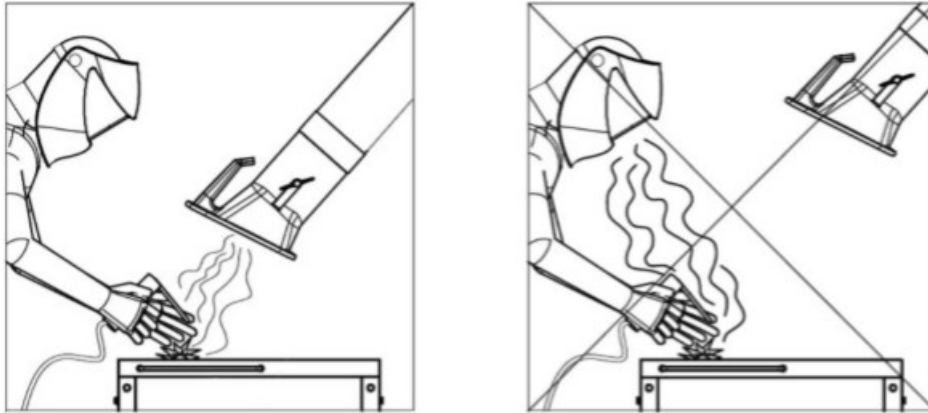

- Adjust the position of the exhaust arm so that the exhaust nozzle is located at an angle and about 25 cm above the point of welding.
- The exhaust nozzle must be set so that, with regard to the thermally conditioned movement of welding fumes and suction reach, it safely collects all welding fumes.
- Always place the exhaust nozzle close enough to the relevant welding point.

Cleaning

Reasonable care will help the LEV to operate effectively and efficiently.

- Clean the ProfiMaster device thoroughly once a month.
- The ProfiMaster device external surface can be cleaned using a suitable vacuum cleaner of dust class H or alternatively wiped with a damp cloth.
- When cleaning the exhaust arm, also remove the accumulated dust or other deposits on the protective grid (optional accessory), or inside the exhaust nozzle respectively.
- Check the hose of the exhaust arm for damage such as spark holes or worn spots.

Maintenance

The ProfiMaster requires a service on an annual basis by qualified personnel

Filter replacement

The service life of the filter elements depends on the type and quantity of the separated particles

It is recommended to change the pre-filter mat regularly according to the volume of work, e.g. daily or weekly and not waiting until it is completely covered with dust.

Increasing filter clogging with dust makes the flow resistance grow and hence the unit performance is reduced.

In most cases it is sufficient to replace the pre-filter mat. The Main filter should be replaced only after replacing the pre-filter mat several times.

The horn starts sounding in case of a drop below the minimum volume flow.

Cleaning of filter elements is not allowed. This would inevitably damage the filter medium, hence the filter would lose its function and hazardous substances would pollute the inhaled air.

Emergency measures

In case of fire of the filtration device or its absorptive parts proceed as follows:

- If possible, unplug the ProfiMaster device by pulling the power plug from the power supply.
- Extinguish the fire by conventional powder fire extinguishers.
- Alternatively, notify the local fire brigade.

Do not open the filtration device service door, risk of flame flaring!

In the event of fire do not touch the device in any case without suitable protective gloves. Danger of burns!

DO IT RIGHT FIRST TIME!

1. COMMUNICATE PRE-WELDING JOB
2. COMPLETE THE PRE-USE LEV CHECKS
3. ASSESS THE RISK TO YOURSELF AND THOSE AROUND
4. ASSESS THE WELDING REQUIRED
5. ENSURE THE CORRECT POSITIONING OF THE LEV
6. ENSURE YOU HAVE APPROPRIATE RPE
7. CLEAR UP

Safe System of Work – LEV				Page 5 of 5	
Document Ref:	SSW004	Issue:	1	Date:	06/19